

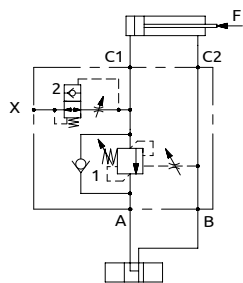

## Valvola di bilanciamento semplice effetto, serie 165, con valvola paracadute Single overcenter valve "165 series" with hoseburst valve

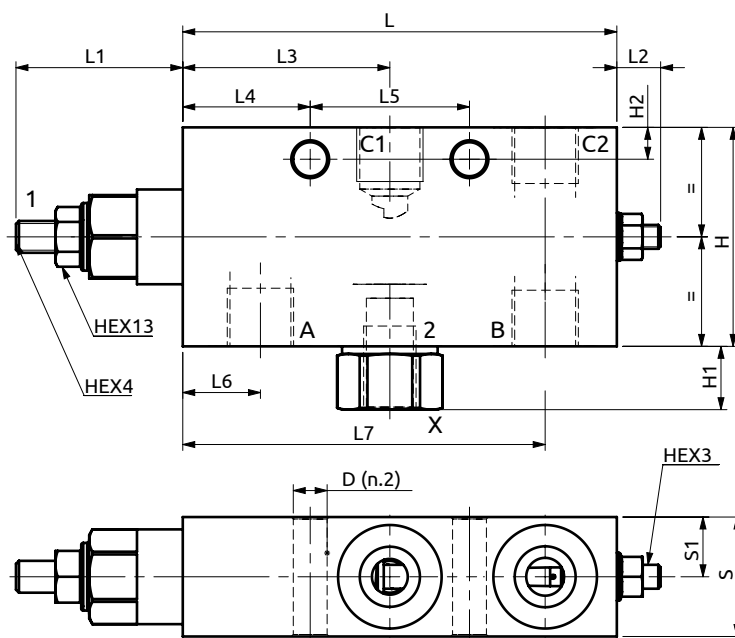

CURVE CARATTERISTICHE  
PERFORMANCE CURVES

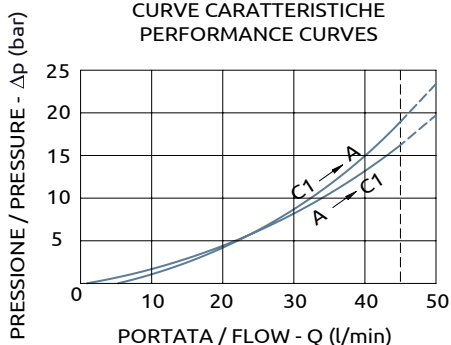

### Corpo in acciaio / Steel body

109	~42	~10	52	32	40	19.5	91	30	15	55	16	8	Ø8.5
L	L1	L2	L3	L4	L5	L6	L7	S	S1	H	H1	H2	D

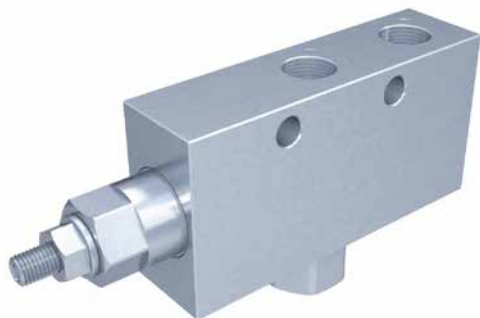

### DESCRIZIONE

Valvola di bilanciamento a semplice effetto, consigliata per distributori con spole a centro aperto in neutro. Collegare all'impianto come da schema. La valvola permette: flusso libero da A verso C1, sostentamento del carico con distributore in neutro o a pompa ferma, controllo del movimento di discesa del carico a seguito del pilotaggio della valvola pilotaggio, protezione da sovrappressioni nel cilindro. La valvola integra la valvola paracadute (2) sull'attacco X.

Single overcenter valve, suggested for use with open centre spools. To be connected as shown. The valve allows: free flow from A to C1, to hold the load with spool in neutral position or with the pump not running, controlled movement when pilot pressure is applied, relief function against overpressure in the cylinder. A hose burst valve is fitted inside the X port.

CODICE ORDINAZIONE  
PIOMBATURA

SEALING ORDERING  
CODE

916003

Codice Ordinazione	Rapporto di Pilotaggio	Campo di Taratura	Taratura Standard	Incremento per Giro	Portata Massima	Pressione Max	Dimensione Porte	Peso	
Ordering Code	Pilot Ratio	Pressure Range	Standard Setting	Pressure Increase	Max Flow	Max Pressure	Port Size	Weight	
A060361.04.00	2.7:1	80-350 bar	300 bar	85 bar/turn	45 l/min	500 bar	A, B, C1, C2 X	3/8"G 1/4"G	1.4 kg
A060361.05.00	4.3:1	80-350 bar	350 bar	135 bar/turn	45 l/min	500 bar	A, B, C1, C2 X	3/8"G 1/4"G	1.4 kg
A060361.06.00	8.8:1	80-350 bar	350 bar	90 bar/turn	45 l/min	500 bar	A, B, C1, C2 X	3/8"G 1/4"G	1.4 kg