

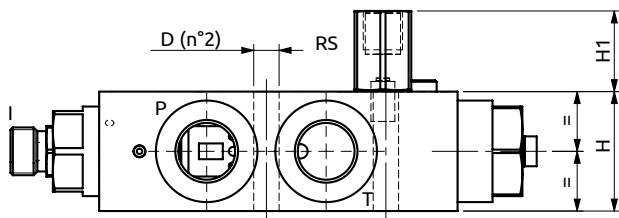

**Blocco integrato limitatore di momento**  
*Load limiting integrated block*

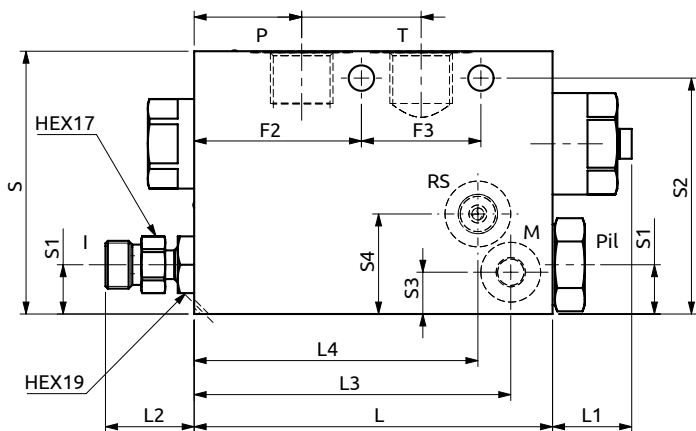
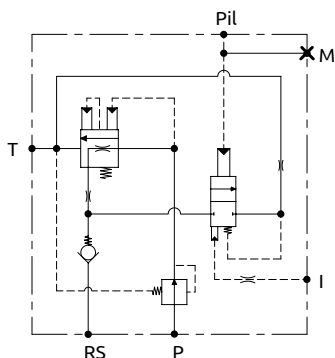

Corpo in alluminio / Aluminium body

A600014.04.00	120	26.5	29.7	106	95	88	16.5	79	14	33.5	40	27	40	36	56	40	Ø8.5	M16x1.5	1/8"G
COD.	L	L1	L2	L3	L4	S	S1	S2	S3	S4	H	H1	F	F1	F2	F3	D	I	M



DESCRIZIONE	DESCRIPTION
Valvola limitatrice di momento. Al raggiungimento della pressione di taratura manda a scarico la linea P (valvola di messa a scarico pilotata del distributore).	Load limiting valve. When the pressure in the circuit reaches the maximum level admitted unload the flow of the port P (normally the piloted unloading valve of the directional valve).

Codice Ordinazione	Campo di Taratura	Taratura Standard	Incremento per giro	Portata Massima	Pressione Max	Dimensione Porte		Peso
Ordering Code	Pressure Range	Standard Setting	Pressure Increase	Max Flow	Max Pressure	Port Size		Weight
A600014.04.00	100-350 bar	250 bar	83 bar/turn	60 l/min	350 bar	P-T	1/2"G	1.7 kg
						Pil-RS	1/4"G	