

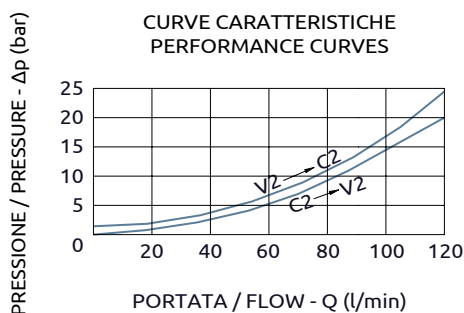

Valvola di bilanciamento semplice effetto, serie SM Single overcentre "SM series"

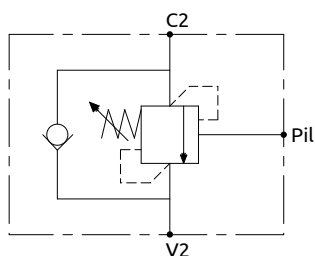

CODICE SEDE

CAVITY CODE

HBS.96.U.03A (Pag. 99.02.01)

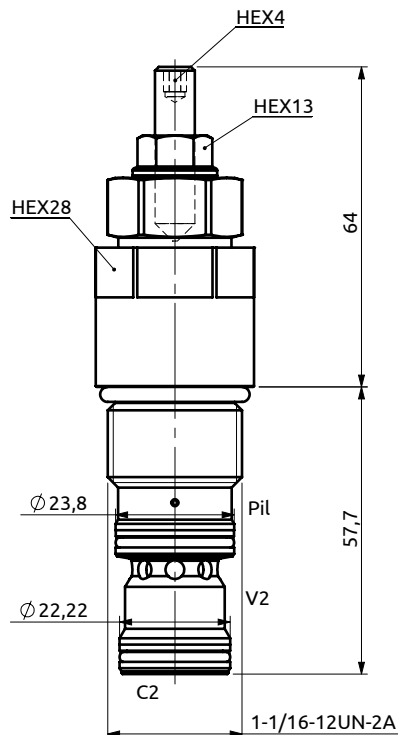

DESCRIZIONE

DESCRIPTION

Valvola di bilanciamento a semplice effetto, consigliata per distributori con spole a centro aperto in neutro. Collegare all'impianto come da schema. La valvola permette: flusso libero da V2 verso C2, sostentamento del carico con distributore in neutro o a pompa ferma, controllo del movimento di discesa del carico a seguito del pilotaggio della valvola pilotaggio, protezione da sovrappressioni nel cilindro.

Single overcenter valve, suggested for use with open centre spools. To be connected as shown. The valve allows: free flow from V2 to C2, to hold the load with spool in neutral position or with the pump not running, controlled movement when pilot pressure is applied, relief function against overpressure in the cylinder.

COPPIA DI SERRAGGIO

INSTALLATION TORQUE

81-95 N*m

Codice Ordinazione	Rapporto di Pilotaggio	Campo di Taratura	Taratura Standard	Incremento per Giro	Portata Massima	Pressione Max	Peso
Ordering Code	Pilot Ratio	Pressure Range	Standard Setting	Pressure Increase	Max Flow	Max Pressure	Weight
C060801.01.00	4:1	60-210 bar	180 bar	42 bar/turn	120 l/min	350 bar	0.4 kg
C060801.03.00	4:1	180-350 bar	200 bar	88 bar/turn	120 l/min	350 bar	0.4 kg