

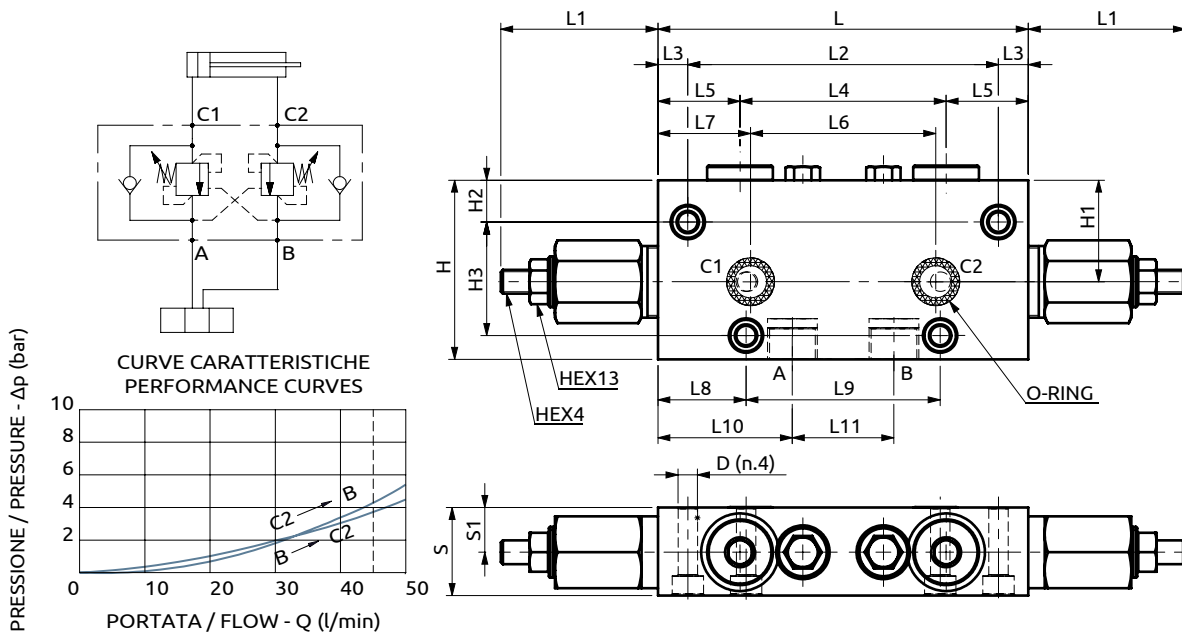

Valvola di blocco bilanciata doppia in linea flangiabile serie BR  
*Flangeable dual overcenter valve in line "BR series"*



Corpo in alluminio / Aluminium body

124	~50	104	10	69	27.5	62	31	29.5	65	45	34	30	15	60	34	14	38	Ø6.5	OR 3043 Ø10.78x2.62
L	L1	L2	L3	L4	L5	L6	L7	L8	L9	L10	L11	S	S1	H	H1	H2	H3	D	O-RING

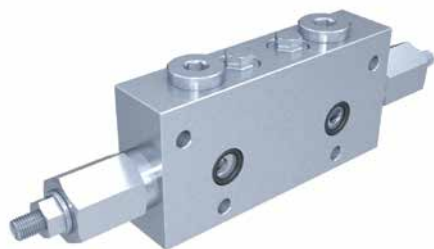

DESCRIZIONE	DESCRIPTION
<p>La valvola permette il flusso libero da A&gt;C1 o B&gt;C2 e il controllo nel verso opposto tramite l'azione della pressione di pilotaggio. Assicura il blocco del carico con distributore in neutro o a pompa ferma (trafilamento max. 5 gocce/min) e permette di scaricare i picchi di pressione se la spola del distributore è a centro aperto. Tarare ad almeno 1,3 volte la pressione massima indotta dal carico. Eventuali contropressioni sullo scarico aumentano la pressione di taratura e di pilotaggio richiesta per pilotare la valvola.</p>	<p>The valve allows free flow from A&gt;C1 or B&gt;C2 and the control in the opposite direction. The load is locked when the spool valve is in neutral position or the pump is not running (max leakage 5 drops/min). Peaks of pressure can be relieved only with open centre spool valves. The valve must be set at 1,3 times the max. load induced pressure. Back pressure downstream the valve increases the setting and the requested pilot pressure.</p>

CODICE ORDINAZIONE PIOMBATURA	SEALING ORDERING CODE
-------------------------------	-----------------------

916003

Codice Ordinazione	Rapporto di Pilotaggio	Campo di Taratura	Taratura Standard	Incremento per Giro	Portata Massima	Pressione Max	Dimensione Porte	Peso
Ordering Code	Pilot Ratio	Pressure Range	Standard Setting	Pressure Increase	Max Flow	Max Pressure	Port Size	Weight
A070316.01.00	4.84:1	50-350 Bar	350 Bar	125 Bar/turn	45 L/min	350 Bar	3/8" g	0.8 Kg
A070316.02.00	6.83:1	50-450 Bar	350 Bar	175 Bar/turn	45 L/min	350 Bar	3/8" g	0.8 Kg