

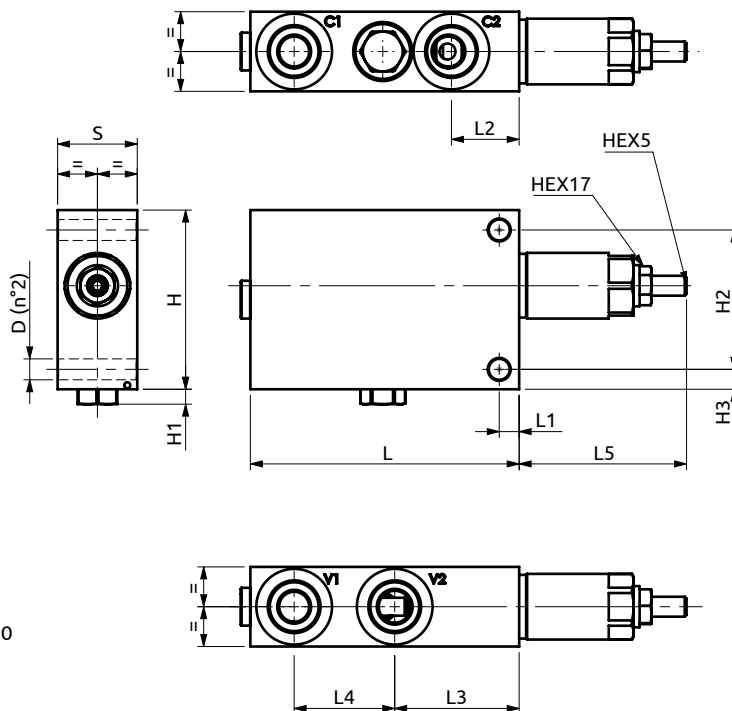

Valvola di bilanciamento semplice effetto, serie BR

Single overcenter valve "BR series"

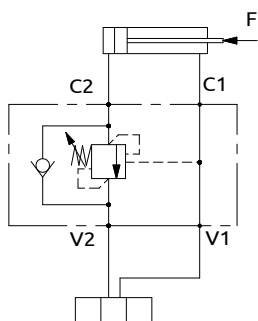

CURVE CARATTERISTICHE
PERFORMANCE CURVES

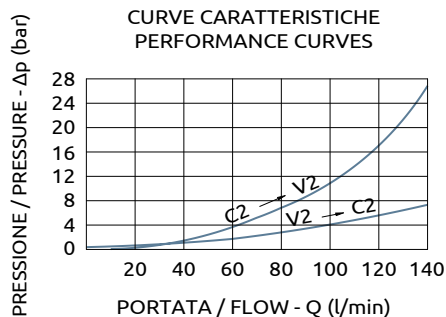

Corpo in acciaio / Steel body

A060600.01.00	135	10	34	62.5	50.5	83	40	90	7.5	70	10	Ø10.5
COD.	L	L1	L2	L3	L4	L5	S	H	H1	H2	H3	D

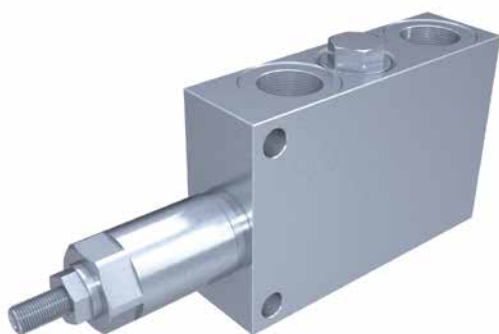

DESCRIZIONE

Valvola di bilanciamento a semplice effetto, consigliata per distributori con spole a centro aperto in neutro. Collegare all'impianto come da schema. La valvola permette: flusso libero da V2 verso C2, sostentamento del carico con distributore in neutro o a pompa ferma, controllo del movimento di discesa del carico a seguito del pilotaggio della valvola pilotaggio, protezione da sovrappressioni nel cilindro.

DESCRIPTION

Single overcenter valve, suggested for use with open centre spools. To be connected as shown. The valve allows: free flow from V2 to C2, to hold the load with spool in neutral position or with the pump not running, controlled movement when pilot pressure is applied, relief function against overpressure in the cylinder.

CODICE ORDINAZIONE
PIOMBATURA

SEALING ORDERING
CODE

916005

Codice Ordinazione	Rapporto di Pilotaggio	Campo di Taratura	Taratura Standard	Incremento per Giro	Portata Massima	Pressione Max	Dimensione Porte	Peso
Ordering Code	Pilot Ratio	Pressure Range	Standard Setting	Pressure Increase	Max Flow	Max Pressure	Port Size	Weight
A060600.01.00	4.4:1	100-350 bar	350 bar	90 bar/turn	140 l/min	400 bar	3/4"G	3.4 kg