

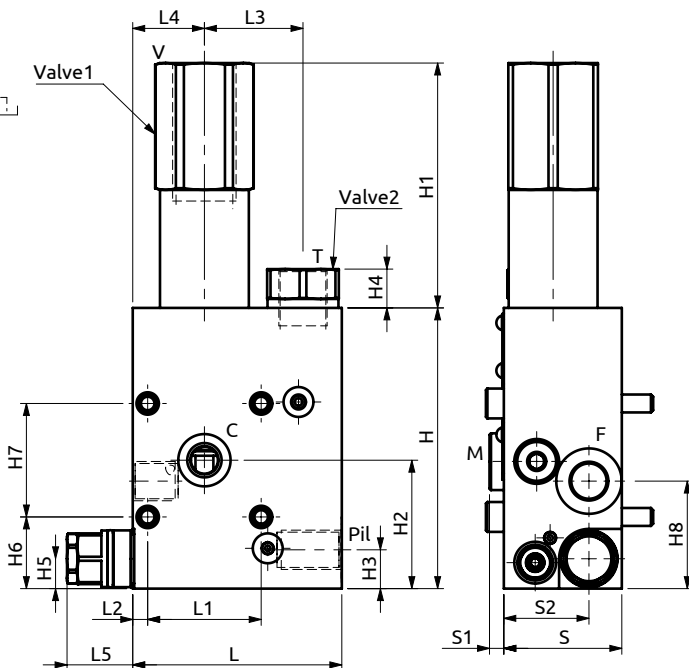

Valvola di bilanciamento semplice effetto flangiabile con anti-shock  
*Flangeable single overcenter valve with anti-shock*

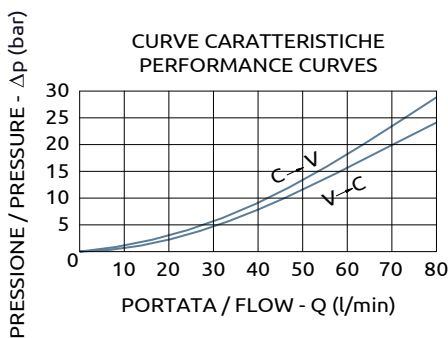
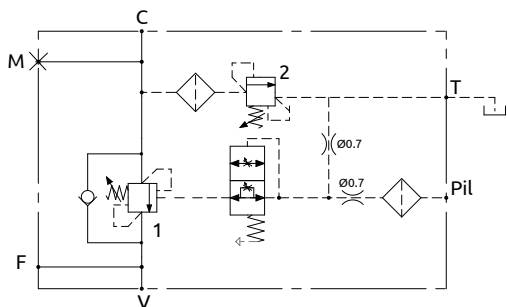

Corpo in acciaio / Steel body

A060471.19.00	70	38	5	33	24	22	39.5	4.8	28.5	94	82	43	13	13	10	24	38	36
COD.	L	L1	L2	L3	L4	L5	S	S1	S2	H	H1	H2	H3	H4	H5	H6	H7	H8

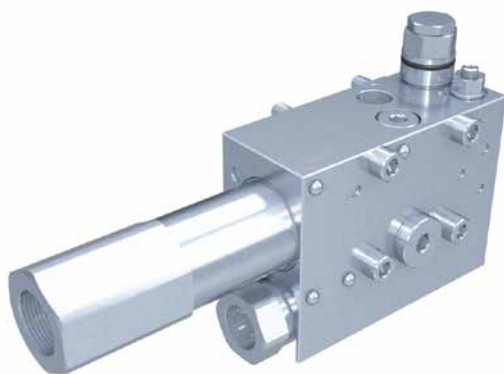

DESCRIZIONE	DESCRIPTION
<p>Valvola di bilanciamento a semplice effetto, consigliata per distributori con spole a centro aperto in neutro. Collegare all'impianto come da schema. La valvola permette: flusso libero da V verso C, sostentamento del carico con distributore in neutro o a pompa ferma, controllo del movimento di discesa del carico a seguito del pilotaggio della valvola pilotaggio, protezione da sovrappressioni nel cilindro. Nella valvola è stata aggiunta la funzione di anti-shock fra cilindro e valvola, con scarico al serbatoio.</p>	<p>Single overcenter valve, suggested for use with open centre spools. To be connected as shown. The valve allows: free flow from V to C, to hold the load with spool in neutral position or with the pump not running, controlled movement when pilot pressure is applied, relief function against overpressure in the cylinder. In the valve there's also the anti-shock function between cylinder and the valve itself, with download to the tank.</p>

Codice Ordinazione	Rapporto di Pilotaggio	Campo di Taratura	Taratura Standard	Incremento per Giro	Portata Massima	Pressione Max	Dimensione Porte	Peso	
Ordering Code	Pilot Ratio	Pressure Range	Standard Setting	Pressure Increase	Max Flow	Max Pressure	Port Size	Weight	
A060471.19.00	3.6:1	150-450 bar	1	400 bar	325 bar	80 l/min	V	1/2"G	2.2 kg
			2	440 bar	144 bar		T	3/8"G	
							Pil, F, M	1/4"G	